

Linux OS

- [Booting](#)
- [System Console](#)
- [User Management](#)
- [Updating](#)
- [System Overview](#)
- [Restoring Factory Settings](#)
- [Building Custom System Image](#)

Booting

Tiger City IMX Industrial Computer with Linux OS

- eMMC
- SD card
- Booting after the power-off command

eMMC

DIP switches positions

To boot from the eMMC the DIP switch No. 1 needs to be in the position shown in the picture below.

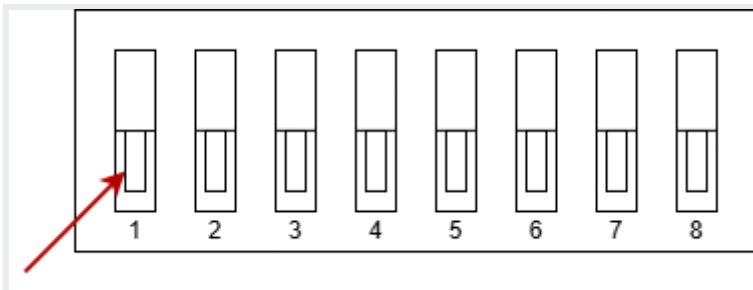

Power supply

Connect a power supply to the pins shown in the picture below. The suggested power supply is a DC voltage in the range of 12-24 V.

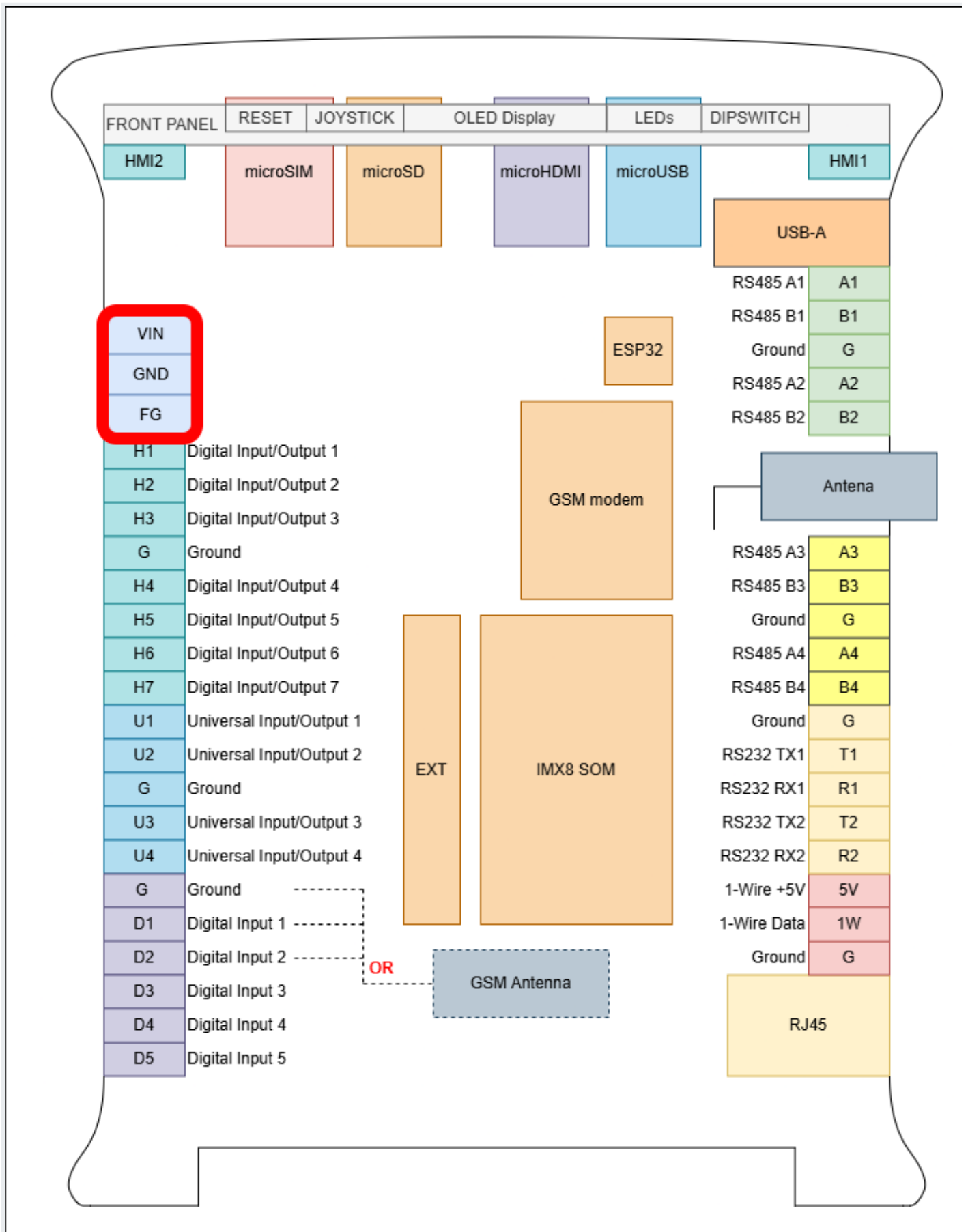

First boot

The connected power supply should initiate the first boot.

Console

Boot logs are displayed in the console, indicating a proper boot from the eMMC, as shown in the picture below.

```
U-Boot SPL 2022.04-1f_v2022.04_var01+g49ec7c516a (Jan 22 2023 - 09:08:56 +0000)
SEC0: RNG instantiated
Normal Boot
Trying to boot from MMC2

U-Boot 2022.04-1f_v2022.04_var01+g49ec7c516a (Jan 22 2023 - 09:08:56 +0000)

CPU: i.MX8MMQ rev1.0 1600 MHz (running at 1200 MHz)
CPU: Industrial temperature grade (-40C to 105C) at 27C
Reset cause: POR
Model: Variscite VAR-SOM-MX8M-MINI
DRAM: 2 GiB
Core: 73 devices, 23 uclasses, devicetree: separate
MMC: FSL_SDHC: 1, FSL_SDHC: 2
Loading Environment from MMC... *** Warning - bad CRC, using default environment

In: serial
Out: serial
Err: serial
extcon_ptn5150_init: Can't find device id=0x3d
extcon_ptn5150_setup: port init failed, err=-19

Part number: VSM-MX8MM-503
Assembly: AS204202761
Production date: 2023 May 03
Serial Number: f8:dc:7a:b1:30:66
switch to partitions #0, OK
mmc2(part 0) is current device
flash target is MMC:2
Net: ADIN1300 PHY detected at addr 4
eth0: ethernet@30be0000
Fastboot: Normal
Normal Boot
Hit any key to stop autoboot: 0
Running BSP bootcmd ...
switch to partitions #0, OK
mmc2(part 0) is current device
Failed to load '/boot/boot.scr'
12823825 bytes read in 42 ms (291.2 MiB/s)
Uncompressed size: 30863872 = 0x1D6F200
Booting from mmc ...
fdt_file=imx8mm-var-som-tiger.dtb
45690 bytes read in 4 ms (10.9 MiB/s)
Moving Image from 0x40480000 to 0x40600000, end=42410000
## Flattened Device Tree blob at 43000000
   Booting using the fdt blob at 0x43000000
   Using Device Tree in place at 0000000043000000, end 000000004300e279

Starting kernel ...
```

SD card

DIP switches positions

To boot from the SD card the DIP switch No. 1 needs to be in the position shown in the picture below.

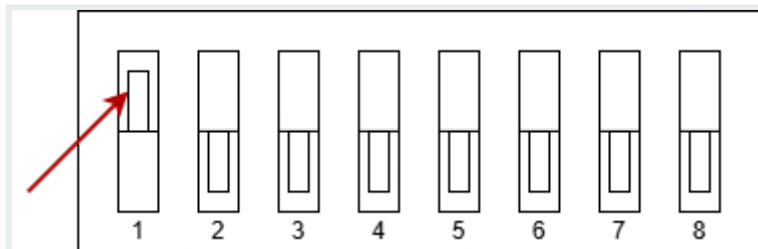

Power supply

Connect a power supply to the pins shown in the picture below. The suggested power supply is a DC voltage in the range of 12-24 V.

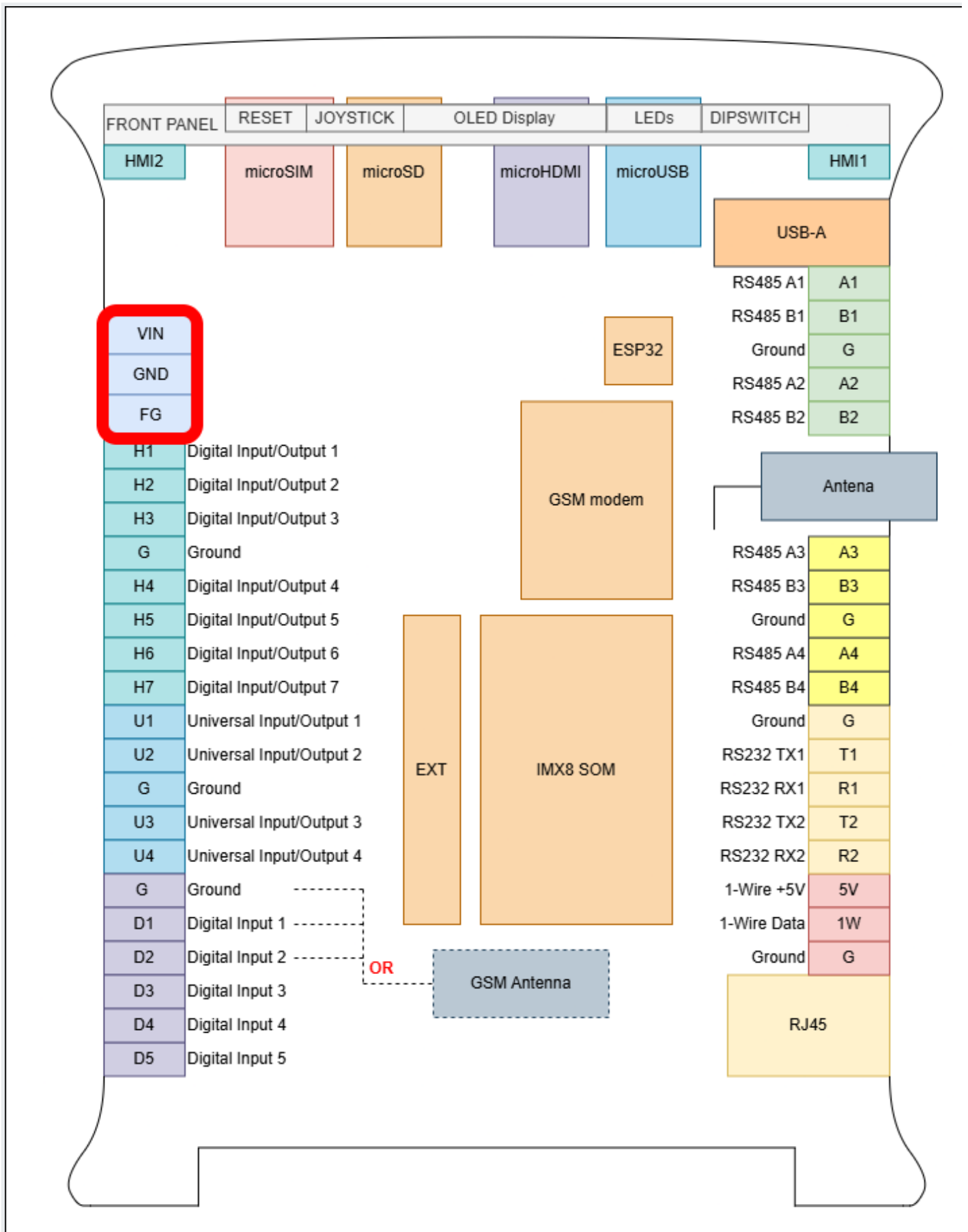

First boot

The connected power supply should initiate the first boot.

Console

Booting logs are displayed in the console.

Booting after the power-off command

If the device is turned off by inputting the power-off command in the terminal, the previous boot methods have to be initiated via the reset button placed on the front panel. Its placement is shown in the picture below.

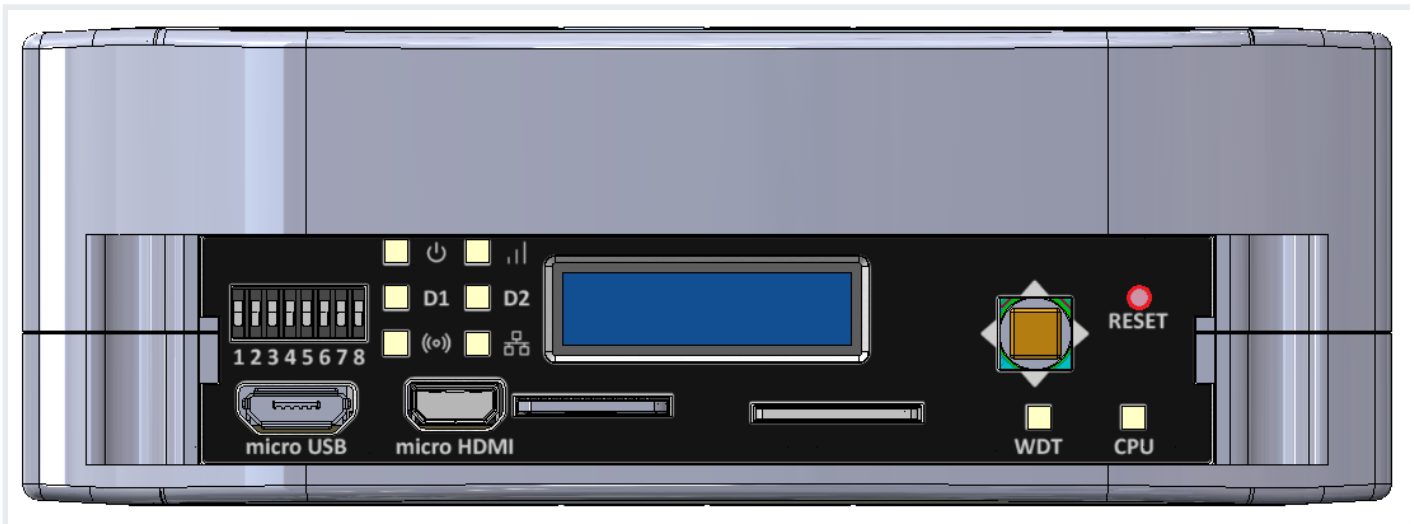

System Console

Tiger City IMX Industrial Computer with Linux OS

UART console

Connecting the adapter to the device

To display the console via UART an RS232 → USB adapter needs to be connected to the pins of the connector shown on the picture below.

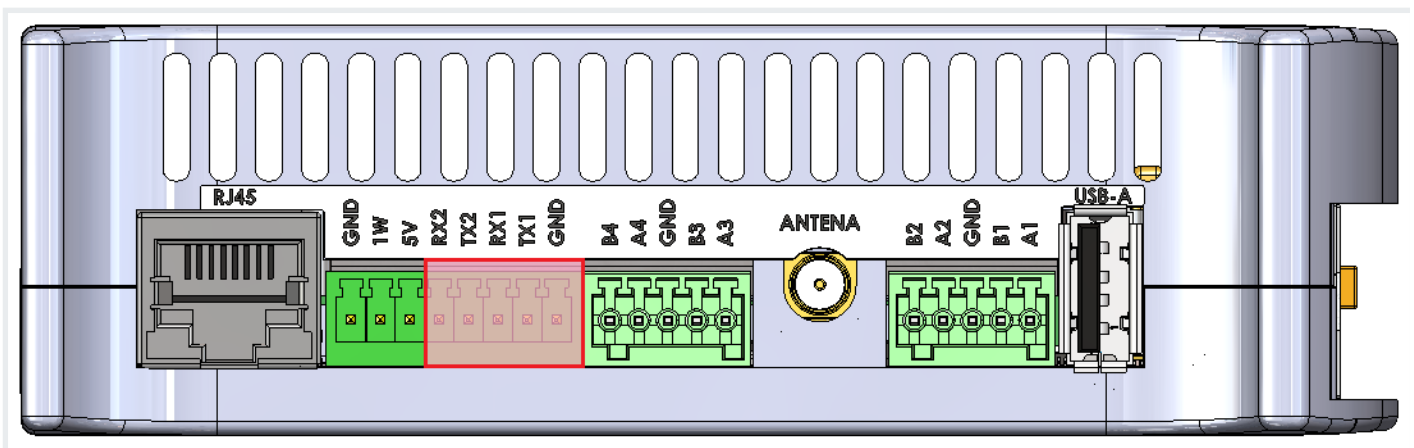

Configuring COM port

A serial port terminal needs to be configured with following configuration:

Bits per second	115200
Data bits	8
Parity	None
Stop bits	1

Then, booting from the chosen source should be realized according to the [instruction](#).

SSH console

Finding an IP of the device

The device's IP can be obtained via 2 methods:

- connecting to the UART console and inputting the “ip a” command when logged as root or other user
- using the joystick shown in the picture below the IP can be displayed on the front panel display



Configuring COM port

The SSH terminal needs to be configured with the IP of the device. Then, booting from the chosen source should be realized according to the [instruction](#).

User Management

Tiger City IMX Industrial Computer with Linux OS

Default user

The default user in Tiger is the only one available after the first boot.

- login: **root**
- no password

Create new users

In order to list all existing users in the system use the following command:

```
awk -F':' '{print $1}' /etc/passwd
```

To add a new user and create a home directory for it use the following command:

```
sudo useradd -m user_name
```

To verify that the user was created and view the user's details use:

```
sudo id user_name
```

To set a new password for the user use the following command:

```
sudo passwd user_name
```

After that, logging in as a new user will be possible. The current user can be checked with the "whoami" command.

Delete users

A user and its home directory can be deleted with the following command:

```
sudo userdel -r user_name
```

Updating

Tiger City IMX Industrial Computer with Linux OS

System Image

A system image (`.swu` file) is required for the update. The image is protected by the image checksum and by the image signature. That means a modified image will not be accepted by the device. Only images from our source allow for updates. It is possible to transition from older images to newer ones and vice-versa.

There are several ways to update Tiger:

- through the Tiger console using a file on internal or external storage (eMMC or USB drive),
- through the Tiger console using a file from an external server (FTP or HTTPS),
- via the built-in update server.

The first two options require access to the console (username and password). The third option does not require a password for the device.

Storage (eMMC or USB drive)

1. Login to the device console
2. Insert external storage or copy the file to Tiger's storage.
3. In the console, type `swupdate -i <filename.swu> -k /etc/default/rsakey.pub`.
4. The update will proceed automatically.

External Server (FTP or HTTPS)

1. Login to the device console
2. For an FTP server, type `swupdate -d -u ftp://<target_ip>/file.swu -a <user>:<password>`.
3. For an HTTPS server, type `swupdate -d -u https://<target_ip>/file.swu -k /etc/default/rsakey.pub`.

4. The update will proceed automatically.

Built-in Update Server

1. Connect the device to the network.
2. Launch a browser on a PC.
3. In the browser, enter `http://<target_ip>:8080`.
4. Select the `.swu` file from the PC storage and confirm the selection.
5. The update will proceed automatically.

Warning! Update files are the default version of firmware. All updates factory reset the device. Make sure you backup all of your important files.

System Overview

Tiger City IMX Industrial Computer with Linux OS

Distribution

Custom Linux distribution based on the Yocto Project. Type `uname -a` to check installed version, kernel, etc.

Supported languages

- English (US)
- English (GB)

User utilities

Text editor

The default available built-in text editor on the device is `vim`.

Wi-Fi

The device is equipped with a Wi-Fi module and a NetworkManager library, which allows it to connect to nearby wireless networks.

How to enable and connect with WLAN:

1. Check the library status: `systemctl status NetworkManager`
2. If NetworkManager is disabled, type `systemctl start NetworkManager`
3. It is possible to enable it always with autostart: `systemctl enable NetworkManager`
4. Search available networks: `nmcli dev wifi list`

5. Connect with your chosen network: `nmcli dev wifi connect <name> password <password>`
6. Check your connection status with `nmcli connection show --active` OR `ifconfig`

System libraries

List of some commonly used available packages:

- Network Manager
- Modem Manager
- Chromium
- Gawk
- OpenCL
- Bzip2
- C++
- Python 3
- SQLite3
- OpenSSL
- Perl 5
- Curl
- Git
- Debuginfo
- glib
- i2c-tools
- GPIO mockup
- gthread
- iperf
- microhttpd
- rpmbuild
- SSL
- swupdate
- Wayland
- Weston
- XCB
- rpm-plugins
- sudo
- xtables

And much more. All the preinstalled system libraries can be found in `/usr/lib` directory.

User can install any other necessary libraries.

Drivers

System drivers can be displayed using `lsmod` command.

Restoring Factory Settings

Tiger City IMX Industrial Computer with Linux OS

To factory reset the device, you need to reinstall the current system version or perform an update. The entire process is detailed in the [Updating](#) section.

Building Custom System Image

Tiger City IMX Industrial Computer with Linux OS

If you would like to ask a specific question, please visit our [Contact Us](#) page for any further information.